

X80S FURY Chip Scale Packaged Quad Transceiver Product Brief

The X80S FURY is a Chip-Scale Package (CSP) surface-mount instantiation of a 4-channel transceiver for parallel optical data communications up to 10 Gbps per channel. The X80S FURY integrates into a single reflow solderable package a transceiver IC, a GaAs Vertical Cavity Surface Emitting Laser (VCSEL) array, a GaAs PIN photodetector (PD) array and a glass lens array with a lens guide mechanism allowing registration of the RVCON™ parallel fiber termination. The X80S FURY electrical interface consists of BGA solder balls that can be reflow soldered onto a circuit board. The X80S FURY is designed for hi-reliability systems that require operation in harsh environments, including extended temperature ranges, shock and vibration, temperature cycles and high humidity. It includes advanced built-in-test functionality for continuous monitoring of operating conditions, both internal IC status and external parameters, such as fiber optic link-loss and signal quality.

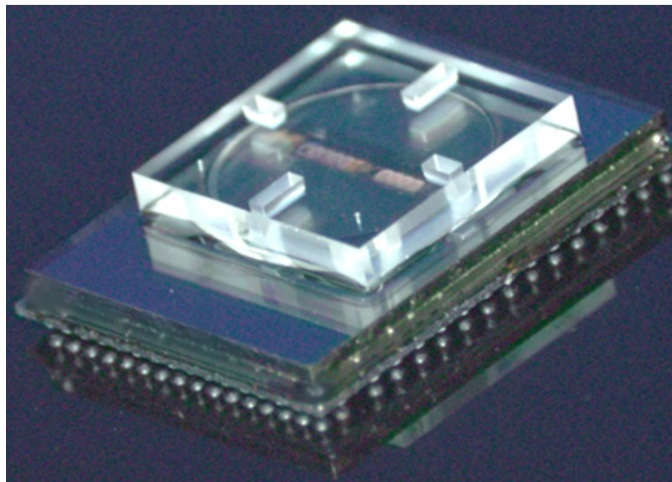

FEATURES:

- Operating data rate: 10 Mbps to 10 Gbps per channel
- SMT reflow solderable package
- Removeable connector/fiber termination
- 850 nm VCSEL transmitter
- Package size: 7.7 x 10 mm
- Supply voltage: 3.3 V
- Radiation tolerant circuitry
- Temperature range: -40 to +85°C
- Module management, controls, and diagnostics through SPI
- High Rx dynamic range with AGC (Automatic Gain Control)
- Individual channel power-down and squelch

BUILT-IN-TEST (BIT):

- ASIC temperature
- VCSEL voltage
- Supply voltage
- RSSI – average RX optical power monitoring

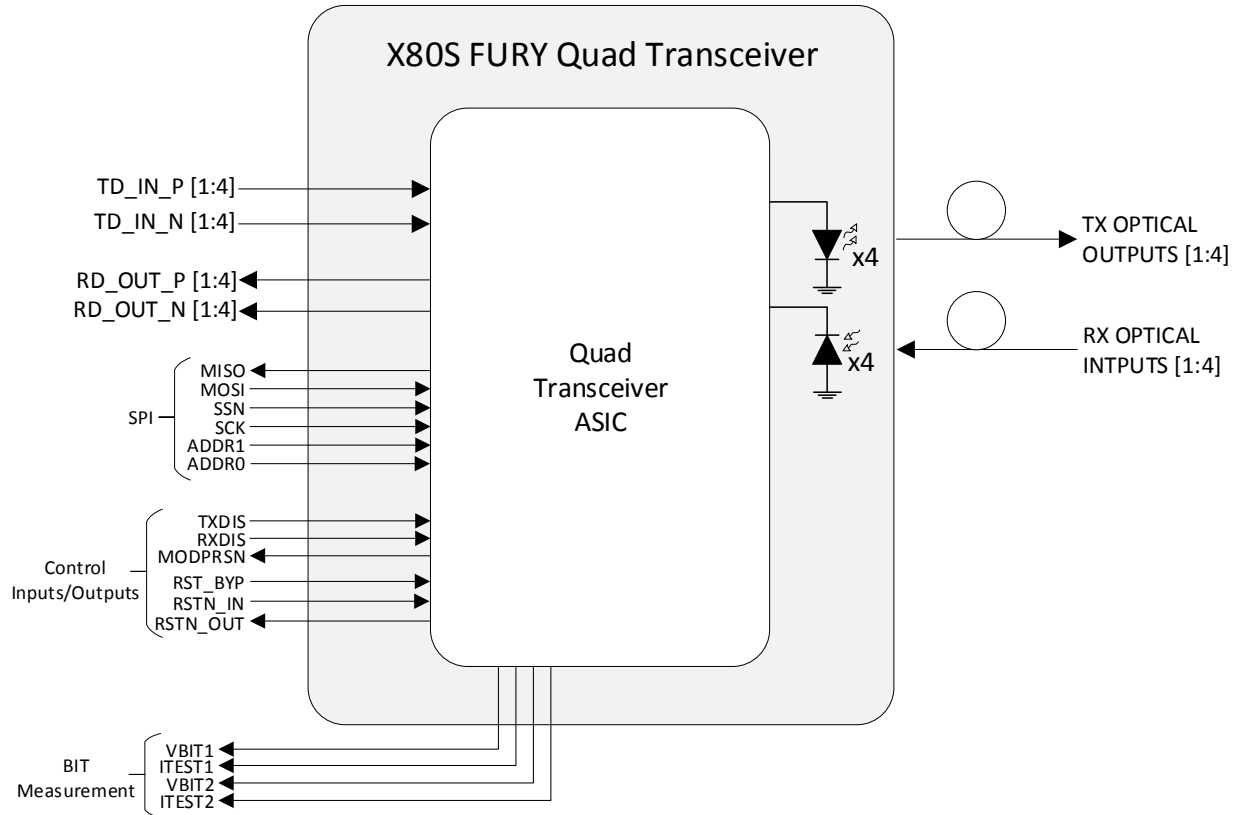

Figure 1: Block Diagram

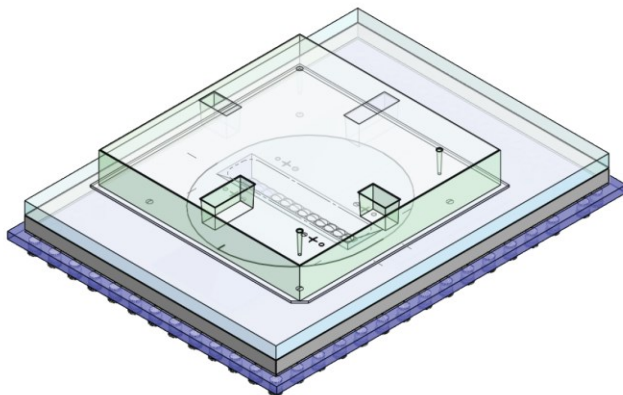

Figure 2: Top view of X80S Fury transceiver

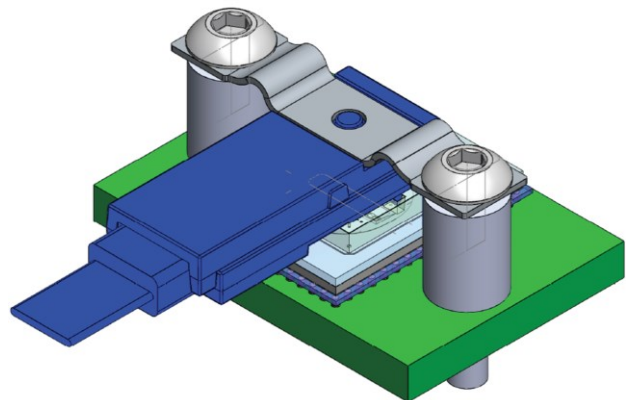

Figure 3: X80S Fury transceiver assembled onto PWB with RVCON™ cable attached

Copyright © 2019. Ultra Communications retains the right to make changes to its products or specifications to improve performance, reliability or manufacturability. All information in this document is subject to change without notice. Furthermore, the information contained herein does not convey to the purchaser any license under the patent right of

990 Park Center Drive, Suite H
 Vista, CA 92081, USA
 Tel: (760) 420-3486
www.ultracomm-inc.com
sales@ultracomm-inc.com